

Cod. Code 7009756	Peso totale Total weight 30 Kg	Materiale Construction GHISA EN-GJL-250 CAST IRON EN-GJL-250	Girante Impeller TRITURATORE GRINDER
-----------------------------	--	--	--

Idraulica - Hydraulic	
MANDATA DISCHARGE	40 mm
ASPIRAZIONE SUCTION	- mm
PASSAGGIO LIBERO FREE PASSAGE	6 mm
DIAMETRO GIRANTE IMPELLER DIAMETER	136 mm

Motore- Motor		M272M-1,1-230/50NY-IE		
ALIMENTAZIONE POWER SUPPLY	1ph 230V-50Hz			
CLASSE DI ISOLAMENTO INSULATION CLASS	H			
VELOCITÀ NOMINALE NOMINAL SPEED	2754 rpm			
POTENZA NOMINALE MOTORE RATED MOTOR POWER	1,1 kW			
CORRENTE DI SPUNTO STARTING CURRENT	24,4 A			
CORRENTE NOMINALE RATED CURRENT	6,6 A			
MOMENTO DI INERZIA TOTALE TOTAL MOMENT OF INERTIA	0,0021 kgm2			
	CARICO-LOADING			
	4/4	3/4	1/2	
FATTORE DI POTENZA POWER FACTOR	0,99	0,97	0,93	
RENDIMENTO MOTORE MOTOR EFFICIENCY	73 %	72 %	72 %	

Impiego - Application	
TEMP. MAX DEL LIQUID PUMPED LIQUID MAX TEMP.	< 40 °C
PROTEZIONE MECCANICA MECHANICAL PROT. DEGREE	IP 68
CAVO CABLE	4G1,5 H07RNF
CODICE DISEGNO DRAWING CODE	707_40_72_3
CURVA CURVE	T707-230

Rend. max - Best efficiency	
RENDIMENTO TOTALE TOTAL EFFICIENCY	17,3 %
RENDIMENTO IDRAULICO HYDRAULIC EFFICIENCY	23,7 %
POT. ASS. DALLA RETE ABS. POWER FROM MAINS	1,2 kW
PREVALENZA HEAD	8,7 m
PORTATA CAPACITY	8,5 m³/h

Protezioni - Protections	
PROTEZIONE TERMICA THERMAL PROTECTION	<input checked="" type="checkbox"/> YES
CONTROLLO INFILTRAZIONE HUMIDITY PROBE	<input type="checkbox"/> NO
II 2G Ex db h IIB T4 Gb	<input type="checkbox"/> NO
MANTELLO DI RAFFREDDAMENTO COOLING JACKET	<input type="checkbox"/> NO

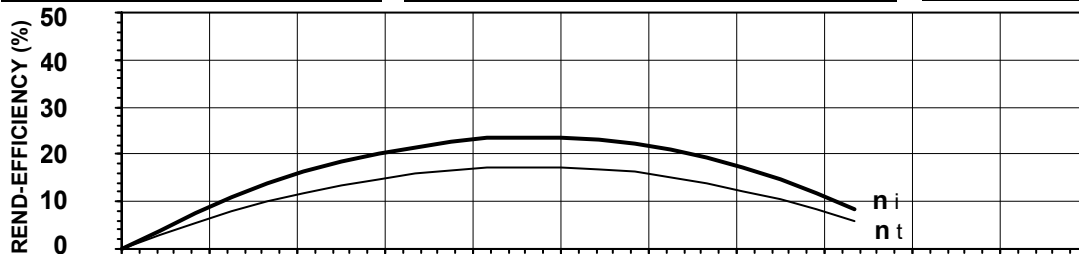

η_i = Rendimento idraulico
Hydraulic efficiency

η_t = Rendimento totale
Total efficiency

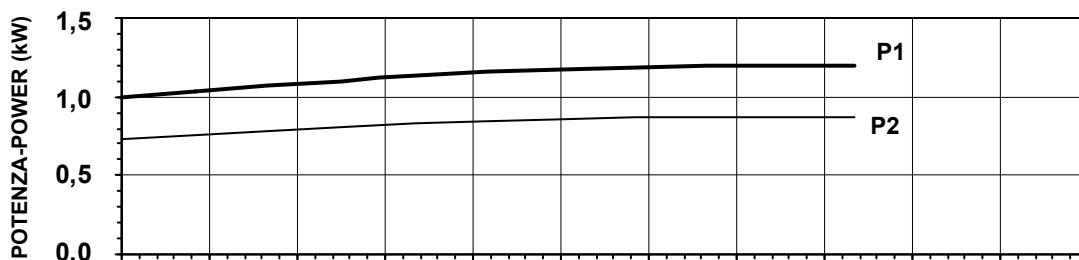

P1 = Potenza ass. dalla rete
Abs. power from mains

P2 = Potenza idraulica
Hydraulic power

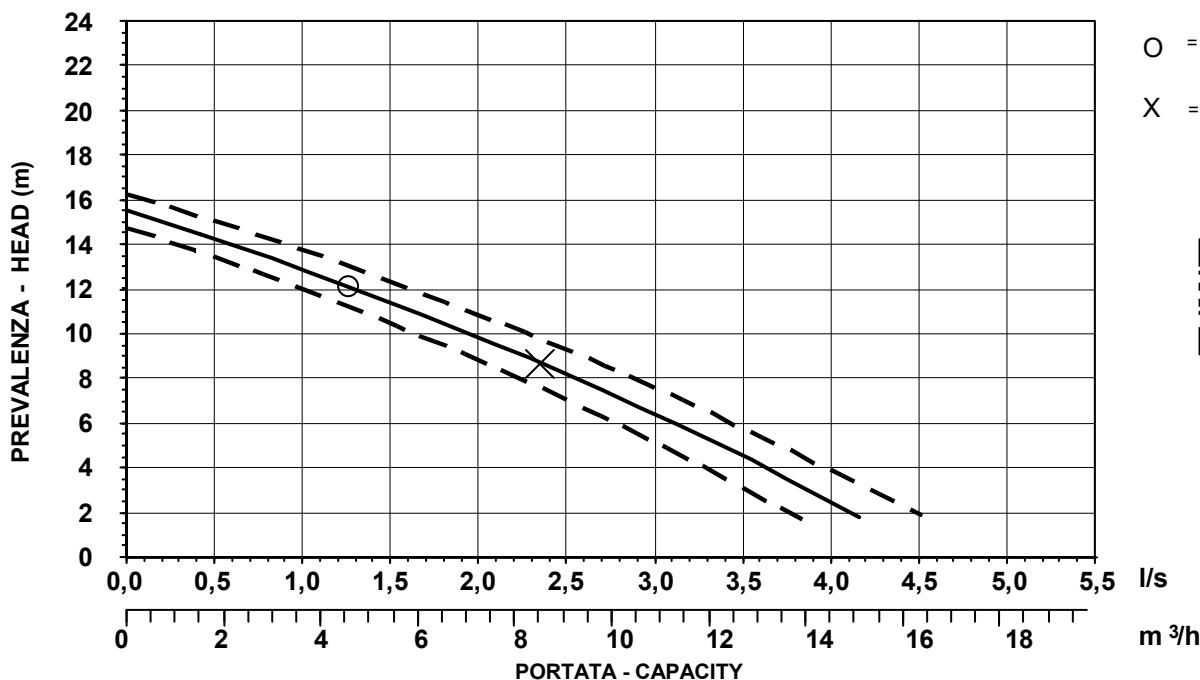

O = Portata minima
Minimum capacity

X = Punto max rendimento
Best efficiency point



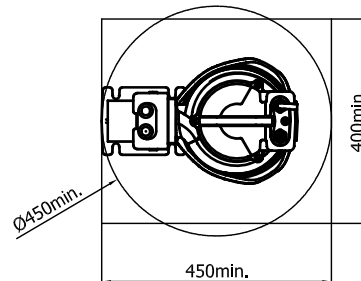
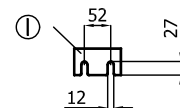
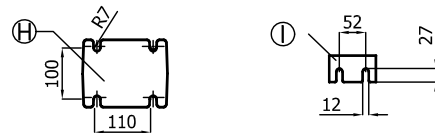
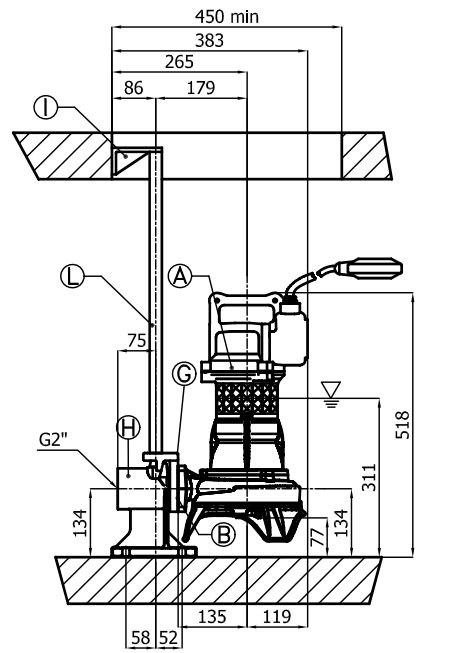
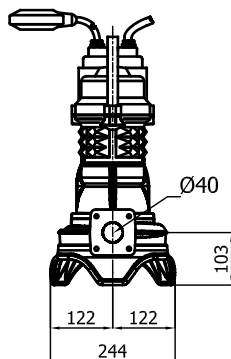
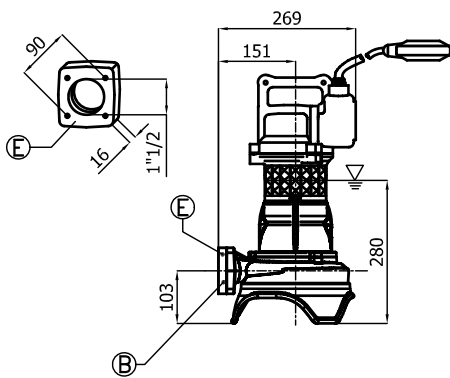
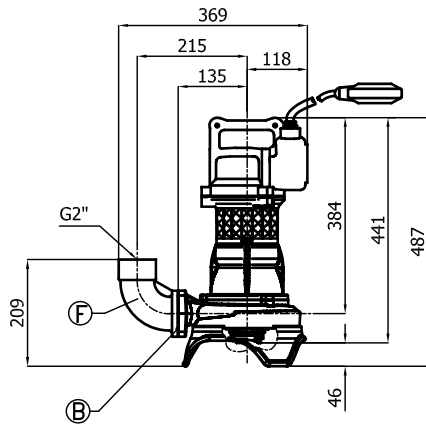

R

Pos.	Codice	Descrizione	Materiale	Peso Kg
Pos.	Code	Description	Material	Weight Kg
A	-	Elettropompa Sommersibile Submersible Pump		-
B	54.09310	Guarnizione DN50 Rubber joint DN50	Neoprene Neoprene	0,01
Type: P				
E	GF1.1/2T	Flangetta filettata 1"1/2 Threaded flange 1"1/2	G250 Ghisa G250 Cast-Iron	1
F	GCF2	Curva filettata 90° 2" Threaded elbow 90° 2"	G250 Ghisa G250 Cast-Iron	2,1
Type: R				
GPADN502T				
G	GCADN50	Controflangia accoppiamento 2 guide DN50 Double guide rail coupling flange DN50	GS400 Ghisa GS400 Cast-Iron	1,5
H	GBPACDN502T	Piede d'accoppiamento 2 guide DN50 Double guide coupling feet DN50	G250 Ghisa G250 Cast-Iron	6
I	SOP2TDN50	Sopporto tubi superiore 2 guide 3/4 Double guide rail upper support 3/4	G250 Ghisa G250 Cast-Iron	0,53
L	TG3/4Z	Tubo guida 3/4 Guide rail 3/4	Acciaio zincato Galvanized Steel	-

▽ LIVELLO MINIMO DI SOMMERGIBILITÀ STANDARD.
▽ PER VERSIONE ATEX, COMPLETAMENTE SOMMERSA.

▽ MINIMUM SUBMERSIBLE LEVEL STANDARD.
▽ FOR ATEX TYPE, COMPLETELY SUBMERGED.

P